



## IPS Series Sensor

**305 / 3100 / 525 / 5100 / 7100**

**Photon Counting Intelligent Particle Sensor for Accurate Air Quality Monitoring**  
**Product Specification**

### Product Summary

The Piera IPS is a photon counting readout based highly sensitive optoelectronic particulate sensor. Utilizing Piera's PCIC as a core processor, the IPS is compact and consumes low power while capable of fast data acquisition and readout, as well as categorizing particulates based on the size. The IPS comes in three models – Series 3, 5, and 7 – where number of output bins are three, five, and seven respectively. Please refer to the product lineup page for further details. The IPS features an adjustable sensitivity control that provides superior accuracy and versatility. Using a unique algorithm to identify different particulates, the IPS is suitable for true real-time precise airborne particulate matter monitoring. Each Piera IPS has been calibrated with GRIMM 11D in a controlled calibration environment.

### Features

- Ultra-high sensitivity for detecting airborne particulates (PM0.1 – PM10\*)
- Fast data acquisition and sampling
- Supports UART and I<sup>2</sup>C
- IoT/Network support\*
- Plug-and-play
- Adjustable sampling/data acquisition timing
- Sensitivity control\*
- Power saving mode
- Fan control and cleaning mode
- Built-in output data unit conversion options
- Firmware update capability\*
- Built-in VSD (Vape/Smoke Detection) module\*
- High accuracy and reliability
- Small, robust and long-term stability
- Mounting screw holes

### Applications

- Indoor air quality monitoring & management systems
- Ventilation systems
- Smoke/vape detection
- Wide-range particle detection

\* Features may be only available for specific models.

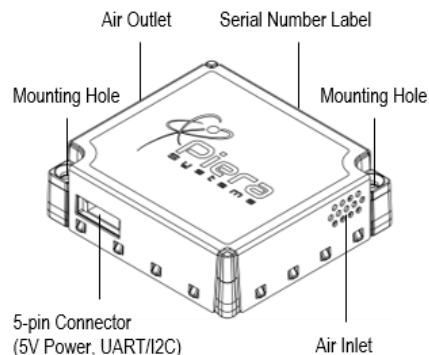

- ⚠ Do not obstruct the air inlet and outlet during operation.
- ⚠ Do not operate in a heavily contaminated environment.
- ⚠ Intended for indoor use. Outdoor conditions may affect the sensor performance.

Piera Systems Inc. reserves the right to make corrections, modifications, enhancements, improvements and other changes to its products and services at any time and to discontinue any product or service without notice. Please contact Piera Systems anytime to obtain the latest relevant information. This datasheet is for firmware versions V1.9.10 or higher.



## Table of Contents

1. Sensor Specifications
2. Electrical Specifications
3. Hardware and Settings
4. Communication Protocols
5. Technical Drawings
6. Product Lineup
7. Ordering Information
8. Important Notices

### 1. Sensor Specifications

Parameter	Conditions	Value	Units
Particle Count (PC) accuracy <sup>1</sup>	-	±10	%
Particle Count (PC) resolution	-	1	#/Liter
Particle Count (PC) limit	Referenced @ 2.5um PC bin	1,000,000	#/Liter
Mass Concentration (PM) limit <sup>2</sup>	Referenced @ ≤2.5um particle size	6,000	ug/m <sup>3</sup>
Binning output range for particle counts (Differential)	PC0.1	≤0.1	um
	PC0.3	0.1 - 0.3	um
	PC0.5	0.3 - 0.5	um
	PC1.0	0.5 - 1.0	um
	PC2.5	1.0 - 2.5	um
	PC5.0	2.5 - 5.0	um
	PC10	5.0 - 10	um
Binning output range for mass concentration (Cumulative)	PM0.1	≤0.1	um
	PM0.3	≤0.3	um
	PM0.5	≤0.5	um
	PM1.0	≤1.0	um
	PM2.5	≤2.5	um
	PM5.0	≤5.0	um
PM10	≤10	um	
Start-up time <sup>3</sup>	Default: 5 (until stable output)	>2.5	s
Count sampling time	Default: 0.2	≥0.1	s
Data output interval	Default: 1	≥0.1	s
Lifetime <sup>4</sup>	24h/day operation	>8	Years
Dimensions	4.6 x 4.15 x 1.24		cm
Weight	26		g

Table 1. Piera IPS specifications

1. Deviation from reference counter (GRIMM 11D model year 2006) based on average readings over 3-minute period. The accuracy is verified after calibration using a Smoke Detector Tester Spray, SDI LLC. Contact Piera Systems for further details.
2. Mass concentration limit is estimated for PC2.5. May vary depending on size and density of particles.
3. Start-up time is 5 second by default. Any data output during this period should be discarded. Subject to change depending on the user settings for the count sampling time.
4. Lifetime may vary depending on different operating conditions.

Piera Systems Inc. reserves the right to make corrections, modifications, enhancements, improvements and other changes to its products and services at any time and to discontinue any product or service without notice. Please contact Piera Systems anytime to obtain the latest relevant information. This datasheet is for firmware versions V1.9.10 or higher.



## 2. Electrical Specifications

### 2.1. Electrical Characteristics

Default conditions of 25°C and 5V supply voltage apply to values in the table below, unless otherwise stated.

Parameter	Conditions	Value	Units
Supply voltage	-	4.5 – 5.5	V
Average supply current	Measurement mode	65	mA
	Sleep mode (UART)	67	uA
	Sleep mode (I <sup>2</sup> C)	273	uA
Input high level voltage (V <sub>IH</sub> )	-	>2.31	V
Input low level voltage (V <sub>IL</sub> )	-	<0.99	V
Output high level voltage (V <sub>OH</sub> )	-	>2.9	V
Output low level voltage (V <sub>OL</sub> )	-	<0.4	V

Table 2. Electrical specifications

### 2.2. Absolute Minimum and Maximum Ratings

Parameter	Rating
Supply voltage VDD	-0.3 to 5.5 V
Interface Select SEL	-0.3 to 4.0 V
Rx, Tx I/Os	-0.3 to 3.3 (<5.5 V)
Operating temperature range	-10 to +60
Storage temperature range	-40 to +80
Operating humidity range	0 to 95% RH (non-condensing)
ESD CDM (Charge Device Model)	±4 kV contact, ±8 kV open air
Operation air flow rate	0.1 LPM

Table 3. Absolute minimum and maximum ratings

### 2.3. Recommended Operation Conditions

The sensor best performs when operated within 10 – 40°C and 20 – 80% RH, should be placed in stable temperature and relative humidity locations.

Avoid operating in a heavily contaminated environment; under excessive ambient light, and/or wind.

## 3. Hardware and Settings

### 3.1. Hardware Interface

The interface connector and the description of the pin layout is shown in Fig. 1. The mating female connector should be 5-pin with 1.5mm-pitch. A sample connector info can be found [here](#).



Fig. 1. Interface connector I/O pins

Pin	Name	Description	Comments
1	VDD	Supply voltage	5V ± 10%
2	Rx	UART: Receiving pin for communication	LVTTTL 3.3V
	SDA	I <sup>2</sup> C: Serial data input/output	
3	Tx	UART: Transmitting pin for communication	LVTTTL 3.3V
	SCL	I <sup>2</sup> C: Serial clock input	
4	SEL	Interface select	Floating: UART
			GND: I <sup>2</sup> C
5	GND	Ground	-

Table 4. Interface connector I/O pin description

### 3.2. Default Settings

Features	Default Settings	Description
Auto Mode	On	IPS starts to readout data once power is on – Plug-and play.
Data Output Interval	1 second	IPS reads out all available bin data every 1 second interval.
PM Data Output	On	IPS reads out mass concentration (PM) data as well as particle counts (PC) data.
Serial Number Output	On	Device serial number is displayed at the end of each data string.
Network Serial Key Output*	On	Device network serial key is displayed at the end of each data string for IoT applications.
Auto Cleaning Mode	On, 1/week	IPS will initiate auto cleaning cycle every week for 10 seconds.
PC Data Output Unit	#/L	Displayed PC data is in number of particles per liter.
PM Data Output Unit	ug/m <sup>3</sup>	Displayed PM data is in micrograms per cubic meter.
VSD Mode*	On	Vape/Smoke Detection feature is standard on IPS-7100 models, and the feature is enabled.
CRC	Off	CRC16 mode disabled.

Table 5. Default settings for UART

\*For equipped models only. Please refer to the Product Lineup section.

## 4. Communication Protocols

### 4.1. Physical Layer

The IPS has Rx and Tx lines with unipolar logic levels. Transmitted byte is shown in Fig. 2. The data speed is 115,200 Baud Rate. The IPS offers both a UART and I<sup>2</sup>C interface.

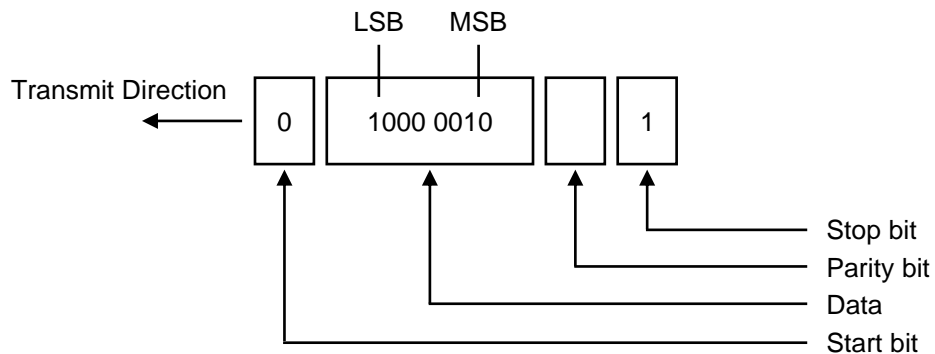

Fig. 2. UART (Universal Asynchronous Receiver Transmitter) data transfer

### 4.2. UART Interface

Fig. 3 shows the typical UART application circuit, which has 5 I/O pins; VDD, Rx, Tx, SEL, and GND. All commands for IPS (slave) are in printable ASCII strings for convenience. The IPS also replies in printable ASCII string format. Therefore, any serial communication program available on PC and application systems (master devices) can be used to download commands and see the results. An UART cable length should be less than 5m, or 16.5ft.

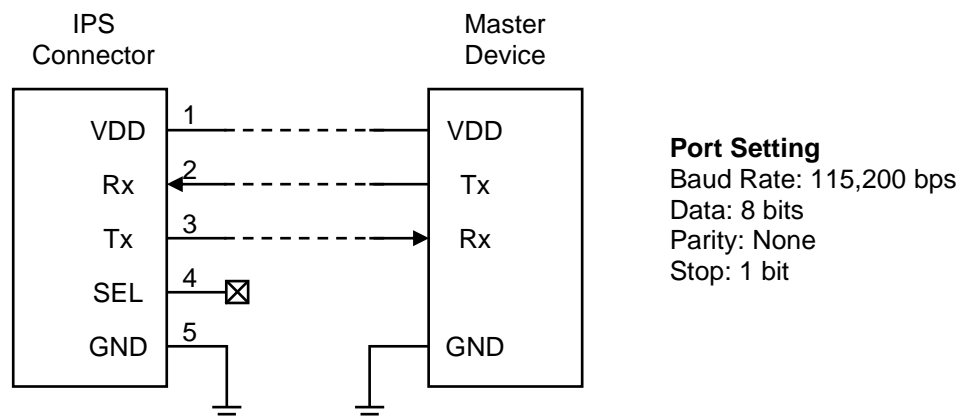

Fig. 3. Typical UART interfacing



#### 4.2.1. Default Sensor Settings

By default, the IPS starts to send data automatically via UART every 1 second as the device is powered up: a series of data strings containing particle counts (PC) and mass concentration (PM) data followed by both device serial number and its network serial key. The PC data is in #/L, and the PM is in  $\mu\text{g}/\text{m}^3$ . Allow at least 5 seconds to obtain stable data. Sensor may send Zero data before this initialization period. The IPS will run self-cleaning cycle for 10 seconds once a week by default.

If your device is equipped with the Vape/Smoke Detection (VSD) algorithm, the VSD mode is on by default. It is standard on IPS-7100 models.

Factory settings:

- |  |                |
|--|----------------|
| 1. Auto Mode                                       | \$Wmodesel=0   |
| 2. 1 second Data Output Interval Time              | \$Winterval=1  |
| 3. PM Data Output                                  | \$Wpmd=1       |
| 4. Output Serial Number and Key Code               | \$Wazure=1     |
| 5. Weekly Auto Cleaning                            | \$Wclnp=604800 |
| 6. Output Unit in #/L and $\mu\text{g}/\text{m}^3$ | \$Wunit=0      |
| 7. Vape-Smoke Detection Mode                       | \$Wvsd=1       |

To reset the sensor to default factory settings, use the following command.

```
$Wfactory=[CR][LF]
```

Note that ENTER key ([CR][LF]) must follow every command.

#### 4.2.2. Operating Mode Setting – Manual or Automatic Mode

The IPS uses simple ASCII strings to communicate between the slave (IPS sensor) and the master device (application system). The internal blow fan is on as power is supplied.

##### Manual Mode:

- a. Set Interval Time

\$Winterval=<n>[CR][LF], where n is interval in second ranging of 0 – 65,535s. Note that “0” doesn’t output any data automatically, it must be polled using \$Rget=.



**Automatic Mode:** Sensor starts operation and outputs data when the sensor is connected to power through USB connector. On this mode, the sensor outputs data automatically without the “Set Interval Time” command when plugged in a master system (like PC). The sensor outputs data according to the set Interval Time.

**a. Set Auto Mode**

`$Wmodesel=0[CR][LF]`

`$Wreset=[CR][LF]`

**b. Change the Interval Time on Automatic Mode**

`$Winterval=<n>[CR][LF]`, where n is interval in second, ranging from 1 to 65,535s.

#### **4.2.3. Real-time Data Retrieving**

The IPS offers a special mode for getting data (PCx and PMx) immediately at any time. This can be used to poll data when Winterval=0 is set.

`$Rget=[CR][LF]` to retrieve a dataset for all PC and PM.

#### **4.2.4. IoT Communication Mode**

For models that are equipped with this feature, the IPS sends out its unique network serial key for IoT communication. When the IoT communication mode is enabled, device serial number and network key will be displayed at the end of each data string. The sensor memorizes the previous settings once the mode is set.

`$Wazure=1[CR][LF]` to enable IoT Communication Mode

`$Wazure=0[CR][LF]` to disable IoT Communication Mode

#### **4.2.5. Fan Control and Cleaning Mode**

The fan is automatically on when the power is supplied to the module. To turn on or off the fan manually, use the following commands as below:

`$Wfan=1[CR][LF]` to turn on the fan

`$Wfan=0[CR][LF]` to turn off the fan

`$Wcfn=1[CR][LF]` to initiate the cleaning cycle manually

`$Wcfn=0[CR][LF]` to stop the cleaning cycle manually

`$Wcfnp=<n>[CR][LF]` to set the auto self-cleaning interval where n is interval in second (604,800 by default)

`$Wcfnp=0[CR][LF]` to stop the auto self-cleaning mode



#### 4.2.6. PC and PM Unit Change

To change measured data unit, use the following command:

`$Wunit=<n>[CR][LF]` where  $n=0, 1, 2,$  or  $3$

1 for PC, PM values per  $ft^3$ , 2 for PC, PM value per  $m^3$ , 3 for PC, PM value per *liter*.

The default factory setting is  $n=0$  for count number per *liter* and mass number per  $m^3$ .

#### 4.2.7. Power Saving Mode (PSM)

The IPS can hibernate to save energy depending on applications. The IPS will enter hibernation, disabling power to the sensor. The fan, laser diode will all be turned off, and the CPU also goes into deep-sleep mode ( $<67\mu A, <273\mu A$  for  $I^2C$ ). Any trigger pulse (1ms with 50% duty) will wake up the sensor. It will start gathering data normally.

`$Wpsm=1[CR][LF]` to initiate PSM

#### 4.2.8. Vape/Smoke Detection (VSD) Mode

If equipped, the IPS can function as a vape/smoke sensor. The device will detect any event of vaping or smoking, and it will send out alerts (print strings "Smoke Detected" or "Vape Detected") when the VSD is enabled. The device will continue to readout data normally even when the VSD Mode is on.

This feature is standard on every IPS-7100 models. Other models may be upgraded to access this feature on demand.

`$Wvsd=1 [CR][LF]` to enable VSD Mode

`$Wvsd=0 [CR][LF]` to disable VSD Mode

**Warning: IPS is not meant for replacing standard indoor smoke/fire alarms!**

#### 4.2.9. Cyclic Redundancy Check (CRC)

Supports CRC16 code. Please refer to the CRC16 code functions.

`$Wcrc=1 [CR][LF]` to enable data transfer with CRC code.

`$Wcrc=0 [CR][LF]` to disable CRC code.

Adds CRC16 to the end of data output. Each output line will now include two extra bytes just before [CR][LF].





#### 4.2.10. Low Data Mode (LDM)

LDM can be enabled to reduce the amount of data sent from IPS sensor.

`$Wldm=1 [CR][LF]` to enable low data mode.

`$Wldm=0 [CR][LF]` to set standard data transfer mode.

A data string example for PC0.1, PC0.3, PC0.5, PC1.0, PC2.5, PC5.0, PC10, PM0.1, PM0.3, PM0.5, PM1.0, PM2.5, PM5.0, PM10 is as follows.

```
32750000,8492000,4520500,428500,11500,780,268,0.2736459,0.21894411,0.69106513,0.90588760, 0.95394840,0.98977848,1.8606841
```

Azure Key will not be sent, supports CRC16 code.

If `$Wpmd=0 [CR][LF]` is not used, any PM data will be removed, only sending PC data as an example below.

```
32750000,8492000,4520500,428500,11500,780,268
```

#### 4.2.11. Baud rate

This is to change the data transfer rate.

`$Wuart=1 [CR][LF]` for 9600 bps

`$Wuart=0 [CR][LF]` for 115200 bps

The device resets itself if baud rate is changed via this command, stays the same until any further changes are made. It is recommended to use 9600 bps for LDM mode.

*Note: Terminal connection parameters need to be modified if baud rate change is made, and the device requires reconnect at the new baud rate set.*

#### 4.2.12. Sensitivity and Detection Range Control

The IPS has two outstanding features for detecting various sized particulate matters. The user may customize the IPS depending on applications by adjusting sensitivity control voltage and/or detection range control voltage of the sensor. This feature is available for IPS-5100, IPS-5500, and IPS-7100.

*Note: The user is required to calibrate for any particle size range that is not offered by standard IPS sensor output bins. Piera Systems does not guarantee the accuracy of the data obtained in this mode.*

*Contact Piera Systems for more details.*



### Sensitivity Control

The sensitivity control voltage of IPS is initially set to 1,800mV for general purpose operations. User can adjust the sensitivity of IPS when operating in special environments.

$\$WVref=1800[CR][LF]$  where 1700 means Vref is set to 1,800mV

### Detection Range Control

The IPS has 5 different equally spaced electrical bins to categorize the particulate matters by their sizes. The detection range control voltage of IPS is by default set to 2,500mV for typical measurement environment, which sets 5 internal threshold voltages (Vth1, Vth2, Vth3, Vth4, and Vth5). The parameter should be in between 1500 and 3000.

$\$WVth=2500[CR][LF]$  where 2500 sets the threshold voltages as follows:

Vth1=0.5V, Vth2=1.0V, Vth3=1.5V, Vth4=2.0V, and Vth5=2.5V.

#### 4.2.13. Debugging Mode

The IPS offers a debugging mode for the advanced users who want to develop/modify the algorithm by getting the raw data from the sensor. The user can access to raw ASIC data by enabling debugging mode.

$\$Wdebug=1[CR][LF]$ , where x==1 for enabling the debugging mode, x==0 for disabling the debugging mode, which is the default.

When the command is sent to the module, raw data will be displayed as the following example:

```
$Won=1
Won=1
Turn on sensing for 200 [ms]
Init ...
NO[x],1,1,0,0,1,P[x],4,1,0,0,176,PC0.1, 32750000,PC0.3, 8492000,PC0.5,
4520500,PC1.0, 428500,PC2.5, 11500,PC5.0, 780,PC10, 268,PM0.1, 0.2736459,PM0.3,
0.21894411,PM0.5, 0.69106513,PM1.0, 0.90588760,PM2.5, 0.95394840,PM5.0,
0.98977848,PM10, 1.8606841
NO[x],1,2,0,0,2,P[x],5,6,0,0,22,
NO[x],0,0,0,0,0,P[x],0,0,0,0,0,
NO[x],1,0,0,0,2,P[x],5,0,0,0,47,
NO[x],1,1,0,0,2,P[x],1,7,0,0,40
NO[x],0,0,0,0,0,P[x],0,0,0,0,0,PC0.1, 41003000,PC0.3, 10631984,PC0.5, 5768158,PC1.0,
569905,PC2.5, 15295,PC5.0, 1037,PC10, 89,PM0.1, 0.3426046,PM0.3,
0.27411801,PM0.5, 0.87654443,PM1.0, 1.16225832,PM2.5, 1.22617918,PM5.0,
1.27381481,PM10, 1.30579169
NO[x],0,0,0,0,2,P[x],0,0,0,0,44,
```

Piera Systems Inc. reserves the right to make corrections, modifications, enhancements, improvements and other changes to its products and services at any time and to discontinue any product or service without notice. Please contact Piera Systems anytime to obtain the latest relevant information. This datasheet is for firmware versions V1.9.10 or higher.

Where, N0[x] means 5 bin counting numbers on Vth1, Vth2, Vth3, Vth4, and Vth5 respectively, and P[x] is pulse widths of corresponding bin on every 200ms @ $\$W_{on}=1$ .

The sampling interval can be changed by:  $\$W_{on}=2$  for 500ms,  $\$W_{on}=3$  for 1,000ms, and etc.

*Note: The user is required to calibrate the IPS independently if any of the parameters are changed in this mode.*

Contact Piera Systems for more details.

### 4.3. I<sup>2</sup>C Interface

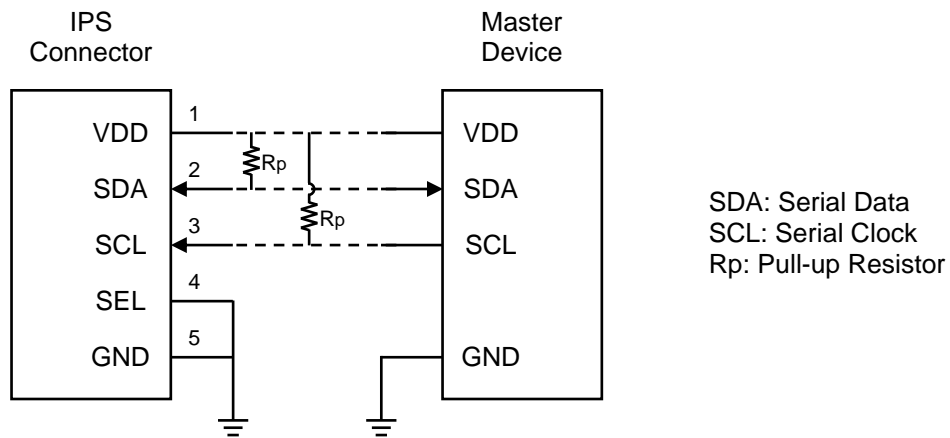

Fig. 4. Typical I<sup>2</sup>C interfacing

SDA is the serial data input/output pin and SCL is the serial clock pin between IPS and a master device. The Rp is pull-up resistor as the SDA and SCL are open drains, and IPS has internal 4.7kΩ resistors built-in. Because the I<sup>2</sup>C interfacing is generally used for communication between short distance devices less than 10cm, a particular attention must be paid to electromagnetic interference and crosstalk with well shielded connection cables/PCB patterns. I<sup>2</sup>C device ID is 0x4b.

*Note: IPS's I<sup>2</sup>C is configured with polling method.*

#### 4.3.1. Header Byte

Write Command: 0x96, Read Command: 0x97

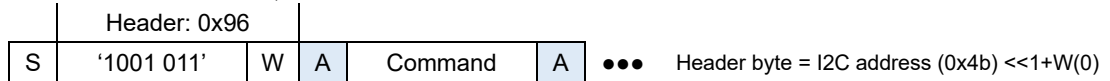



### 4.3.2. Write Format

Command without Data

S	I <sup>2</sup> C address (7)	W	A	Command (8)	A	P
---	------------------------------	---	---	-------------	---	---

I<sup>2</sup>C address (7) = 0x4b

Ex: 0x2d, 0x2e Commands

Command with 1 parameter (1byte)

S	I <sup>2</sup> C address (7)	W	A	Command (8)	A	Parameter (8)	A	P
---	------------------------------	---	---	-------------	---	---------------	---	---

Ex: 0x10, 0x22, 0x23, 0x24, 0x2b, 0x2c Commands

Command with 2 parameters (2byte)

S	I <sup>2</sup> C address (7)	W	A	Command (8)	A	Parameter (8)	A	Parameter (8)	A	P
---	------------------------------	---	---	-------------	---	---------------	---	---------------	---	---

Ex: 0x26, 0x27, 0x28, 0x29 Commands

Command with 4 parameters (4byte)

S	I <sup>2</sup> C address (7)	W	A	Command (8)	A	Parameter (8)	A	Parameter (8)	A
---	------------------------------	---	---	-------------	---	---------------	---	---------------	---

Ex: 0x21 Commands

Parameter (8)	A	Parameter (8)	A	P
---------------	---	---------------	---	---

Write commands are defined on the following table:

CMD	Function	Parameters	Description
0x10	Start/Stop	3,2,1 or 0	Stop measurement (n=0) or start measurement with timer=n, n=1 for 200ms, 2 for 500ms and 3 for 1,000ms
0x21	Set Cleaning Interval	[n1],..., [n4]	[n1]<<24+[n2] <<16+[n3] <<8+[n4]&0xff
0x22	Operation Mode Selection	1 or 0	0: Auto Mode 1: Command Mode Sensor start to outputs data immediately upon powering up when Auto Mode is on, or sensor will wait for Set Interval command at Command Mode before starts
0x23	Power Saving Mode	1 or 0	0x01: Enter Power Saving Mode (<273uA), 0x0: Wake up pulse
0x24	Set Data Unit	[n=0,1,2,3]	For PC: 0 for #/L, 1 for #/ft <sup>3</sup> , 2 for #/m <sup>3</sup> and 3 for #/L For PM: 0 for ug/m <sup>3</sup> , 1 for ug/ft <sup>3</sup> , 2 for ug/m <sup>3</sup> and 3 for ug/L
0x26	Set Vth	[n1], [n2]	Set detection range control voltage [n1] – MSB [n2] – LSB
0x29	Set Vref	[n1], [n2]	Set sensitivity control voltage [n1] – MSB [n2] – LSB
0x2b	Fan Operation	1 or 0	0x01: Start fan, 0x0: Stop fan
0x2c	Start Cleaning	1 or 0	0x01: Start cleaning, 0x0: Stop cleaning
0x2d	Reset	None	Resets the sensor module Allow approx. 5 seconds for normal communication
0x2e	Factory Reset	None	Restore all factory default settings

Piera Systems Inc. reserves the right to make corrections, modifications, enhancements, improvements and other changes to its products and services at any time and to discontinue any product or service without notice. Please contact Piera Systems anytime to obtain the latest relevant information. This datasheet is for firmware versions V1.9.10 or higher.



### 4.3.3. Read Format

Command expecting data from the host

S	I <sup>2</sup> C address (7)	W	A	Command (8)	A	Sr	I <sup>2</sup> C address (7)	R	A
---	------------------------------	---	---	-------------	---	----	------------------------------	---	---

Data1 (8)	A	...	DataN (8)	N	P
-----------	---	-----	-----------	---	---

Ex: 0x11, 0x12, 0x61, 0x62, 0x64, 0x65, 0x66, 0x6a, 0x77, 0x78, 0x79 Commands

S: Start; Sr: Repeat Start; A: Ack; N: Nack; P: Stop

Read commands are defined on the following table:

CMD	Function	Parameters	Description
0x11	Read PC data (3 Series)	[n1],..., [n12] [n13][n14]	Read measured PC data for all 3 bins Each data has 4 unsigned bytes Number of data: [n1~n28] = 4byte x 3 CRC16: [n13]x256+[n14]
	Read PC data (5 Series)	[n1],..., [n20] [n21][n22]	Read measured PC data for all 5 bins Each data has 4 unsigned bytes Number of data: [n1~n28] = 4byte x 5 CRC16: [n21]x256+[n22]
	Read PC data (7 Series)	[n1],..., [n28] [n29][n30]	Read measured PC data for all 7 bins Each data has 4 unsigned bytes Number of data: [n1~n28] = 4byte x 7 CRC16: [n29]x256+[n30]
0x12	Read PM data (3 Series)	[n1],..., [n12] [n13][n14] [n15][n16]	Read measured PM data for all 3 bins Each data has 4 bytes Float (IEEE-754) format The ordering method of the data conversion is Little Endian, i.e, if 4 byte data of ABCD is input, then DCBA is output with real number (floating point number). Number of data: [n1 – n28] = 4byte x 3 EVENT INFO: [n13]x256+[n14] (0: Nothing 1: event 2: smoke 3: vape ... reserved) CRC16: [n15]x256+[n16]
	Read PM data (5 Series)	[n1],..., [n20] [n21][n22] [n23][n24]	Read measured PM data for all 5 bins Each data has 4 bytes Float (IEEE-754) format The ordering method of the data conversion is Little Endian, i.e, if 4 byte data of ABCD is input, then DCBA is output with real number (floating point number). Number of data: [n1 – n28] = 4byte x 5 EVENT INFO: [n21]x256+[n22] (0: Nothing 1: event 2: smoke 3: vape ... reserved) CRC16: [n23]x256+[n24]

Piera Systems Inc. reserves the right to make corrections, modifications, enhancements, improvements and other changes to its products and services at any time and to discontinue any product or service without notice. Please contact Piera Systems anytime to obtain the latest relevant information. This datasheet is for firmware versions V1.9.10 or higher.



	Read PM data (7 Series)	[n1],..., [n28] [n29][n30] [n31][n32]	Read measured PM data for all 7 bins Each data has 4 bytes Float (IEEE-754) format The ordering method of the data conversion is Little Endian, i.e, if 4 byte data of ABCD is input, then DCBA is output with real number (floating point number). Number of data: [n1 – n28] = 4byte x 7 EVENT INFO: [n29]x256+[n30] (0: Nothing 1: event 2: smoke 3: vape ... reserved) CRC16: [n31]x256+[n32]
0x61	Read Cleaning Interval	[n1],..., [n4] [n5][n6]	4 bytes are unsigned integer in second Default value = 604,800 [s] or 1 week CRC16: [n5]x256+[n6]
0x62	Read Mode Selection	[n1],..., [n3]	0: Auto Mode 1: Command Mode CRC16: [n2]x256+[n3]
0x64	Read Data Unit	[n1=0,1,2,3] [n2][n3]	For PC: 0 for #/L, 1 for #/ft <sup>3</sup> , 2 for #/m <sup>3</sup> and 3 for #/L For PM: 0 for ug/m <sup>3</sup> , 1 for ug/ft <sup>3</sup> , 2 for ug/m <sup>3</sup> and 3 for ug/L CRC16: [n2]x256+[n3]
0x65	Read Start/Stop	[n1],..., [n4]	Measurement period reading, [n1]x256+[n2] in ms CRC16: [n3]x256+[n4]
0x66	Read Vth	[n1],..., [n4]	Detection range control voltage reading, [n1]x256+[n2] CRC16: [n3]x256+[n4]
0x69	Read Vref	[n1],..., [n4]	Sensitivity control voltage reading, [n1]x256+[n2] CRC16: [n3]x256+[n4]
0x6a	Read Status	n1],..., [n3]	Read status byte (b0: fan on/off, b1: cleaning on/off, b2: PSM on/off) Each bit is 0 for off and 1 for "On" b3=1 is for UART and 0 is for I <sup>2</sup> C. CRC16: [n2]x256+[n3]
0x77	Read Serial Number	[n1],..., [n20]	[n1] – [n18] : Serial Number CRC16: [n19]x256+[n20]
0x78	Read version number	[n1],..., [n16]	[n1] – [n14] : Version number CRC16: [n15]x256+[n16]
0x79	Read Network Serial key	[n1],..., [n26]	[n1] – [n24] : Serial key CRC16: [n25]x256+[n26]

Piera Systems Inc. reserves the right to make corrections, modifications, enhancements, improvements and other changes to its products and services at any time and to discontinue any product or service without notice. Please contact Piera Systems anytime to obtain the latest relevant information. This datasheet is for firmware versions V1.9.10 or higher.



CRC16 code for reference:

```
#define POLY 0x8408

uint16_t CRC16(uint8_t *byte, int len)
{
    int i, j;
    u16 data=0;
    u16 crc=0xffff;

    for(j=0;j<len;j++)
    {
        data = (u16)0xff & byte[j];
        for(i=0;i<8;i++, data >>= 1)
        {
            if((crc & 0x0001) ^ (data & 0x0001))
                crc = (crc >> 1) ^ POLY;
            else
                crc >>= 1;
        }
    }

    crc = ~crc;
    data = crc;
    crc = (crc << 8)|(data>>8 &0xff);

    return crc;
}
```

## 5. Technical Drawings

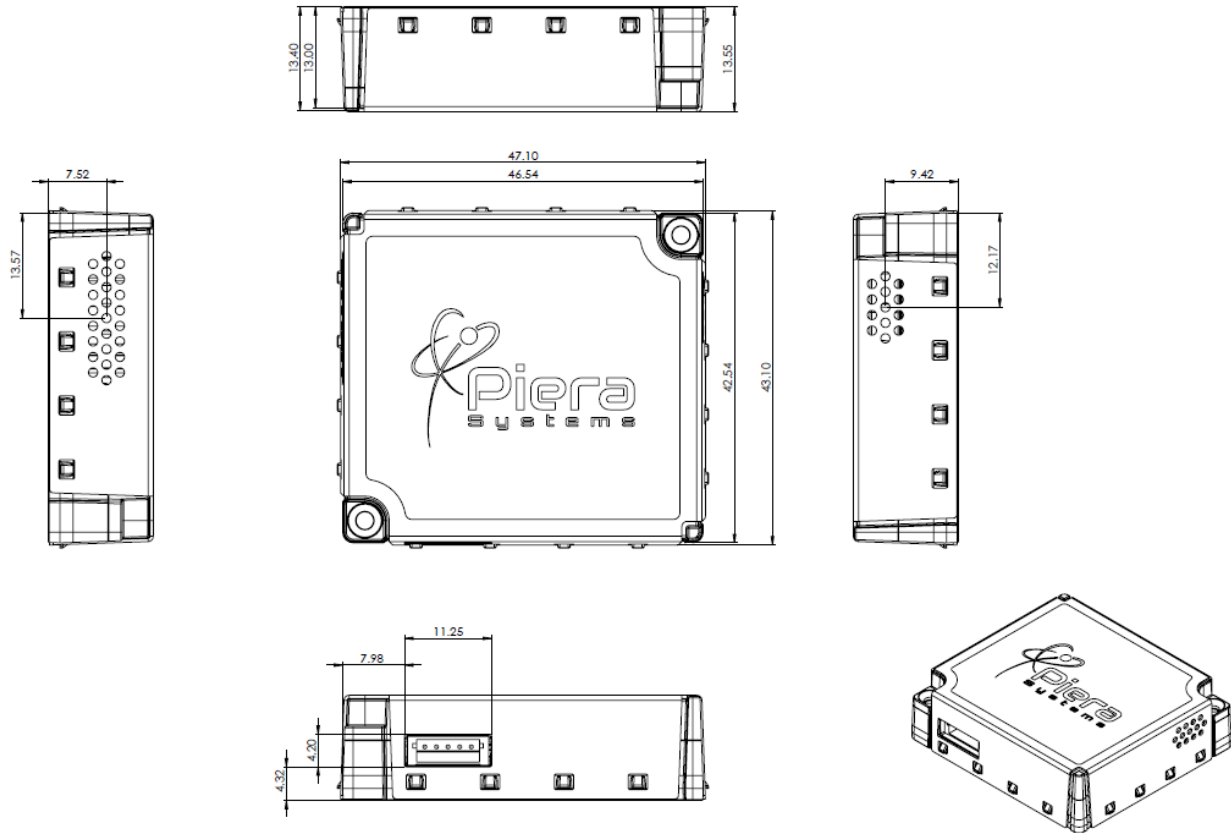

Any IPS models can be mounted by using two M2 screws.





## 6. Product Lineup

Models		Series 3		Series 5		Series 7
		IPS-305	IPS-3100	IPS-525	IPS-5100	IPS-7100
# of Bins		3	3	5	5	7
Binning Output (PM)	0.1	o		o		o
	0.3	o		o		o
	0.5	o		o	o	o
	1.0		o	o	o	o
	2.5		o	o	o	o
	5.0				o	o
	10		o		o	o
Key Features	Output in particle counts	o	o	o	o	o
	Output data unit conversion	o	o	o	o	o
	IoT network support			o	o	o
	USB firmware update			o	o	o
	Customizable sensitivity				o	o
	Customizable binning				o	o
	VSD mode		On-demand	On-demand	On-demand	o

Table 6. IPS series product lineup and features

## 7. Ordering Information

Please visit [www.pierasystems.com](http://www.pierasystems.com) or email to [info@pierasystems.com](mailto:info@pierasystems.com).

## 8. Important Notices

### 8.1. Warning, Personal Injury

**Do not use this product as safety or emergency stop devices or in any other application where failure of the product could result in personal injury. Do not use this product for applications other than its intended and authorized use. Before installing, handling, using or servicing this product, please consult the data sheet and application notes. Failure to comply with these instructions could result in death or serious injury.**

If the Buyer shall purchase or use IPS for any unintended or unauthorized application, Buyer shall defend, indemnify and hold harmless Piera and its officers, employees, subsidiaries, affiliates and distributors against all claims, costs, damages and expenses, and reasonable attorney fees arising out of, directly or indirectly, any claim of personal injury or death associated with such unintended or unauthorized use, even if Piera shall be allegedly negligent with respect to the design or the manufacture of the product.

Piera Systems Inc. reserves the right to make corrections, modifications, enhancements, improvements and other changes to its products and services at any time and to discontinue any product or service without notice. Please contact Piera Systems anytime to obtain the latest relevant information. This datasheet is for firmware versions V1.9.10 or higher.



## 8.2. ESD Precautions

The inherent design of this component causes it to be sensitive to electrostatic discharge (ESD). To prevent ESD-induced damage and/or degradation, take customary and statutory ESD precautions when handling this product.

## 8.3. Warranty

Piera warrants solely to the original purchaser of this product for a period of 12 months (one year) from the date of delivery that this product shall be of the quality, material and workmanship defined in Piera's published specifications of the product. Within such period, if proven to be defective, Piera shall repair and/or replace the product, in Piera's discretion, free of charge to the Buyer, provided that:

- notice in writing describing the defects shall be given to Piera within 14 (fourteen) days after their appearance;
- such defects shall be found, to Piera's reasonable satisfaction, to have arisen from Piera's faulty design, material, or workmanship;
- the defective product shall be returned to Piera at the Buyer's expense; and
- the warranty period for any repaired or replaced product shall be limited to the unexpired portion of the original period.

This warranty does not apply to any equipment which has not been installed and used within the specifications recommended by Piera for the intended and proper use of the equipment.

EXCEPT FOR THE WARRANTIES EXPRESSLY SET FORTH HEREIN, PIERA MAKES NO WARRANTIES, EITHER EXPRESS OR IMPLIED, WITH RESPECT TO THE PRODUCT. ANY AND ALL WARRANTIES, INCLUDING WITHOUT LIMITATION, WARRANTIES OF MERCHANTABILITY OR FITNESS FOR A PARTICULAR PURPOSE, ARE EXPRESSLY EXCLUDED AND DECLINED.

Piera is only liable for defects of this product arising under the conditions of operation provided for in the data sheet and proper use of the goods. Piera explicitly disclaims all warranties, express or implied, for any period during which the goods are operated or stored not in accordance with the technical specifications.

Piera does not assume any liability arising out of any application or use of any product or circuit and specifically disclaims any and all liability, including without limitation consequential or incidental damages. All operating parameters, including without limitation recommended parameters, must be validated for each customer's applications by customer's technical experts. Recommended parameters can and do vary in different applications.

Piera reserves the right, without further notice, (i) to change the product specifications and/or the information in this document and (ii) to improve reliability, functions and design of this product.



Copyright© 2021, by PIERA SYSTEMS.

SenseiAQ® is a product trademark of PIERA SYSTEMS.

All rights reserved.

---

Piera Systems Inc. reserves the right to make corrections, modifications, enhancements, improvements and other changes to its products and services at any time and to discontinue any product or service without notice. Please contact Piera Systems anytime to obtain the latest relevant information. This datasheet is for firmware versions V1.9.10 or higher.